

**ICKL 2013**

**Pascale Guénon**

**Notating hip hop dance**

The objective of this workshop is to explore notation of one hip-hop choreography with the Laban system of notation, using a set of rules based on “A dictionary of Kinetography Laban/Labanotation” by Albrecht Knust.

After a short introduction of the french choreographer Anthony Egea and his choreography “Urban ballet”, I propose to read some excerpts of my score involving the determination of “place”, the determination of directions as well as distance in all fours and different rotations performed on ground, alone or in combination.

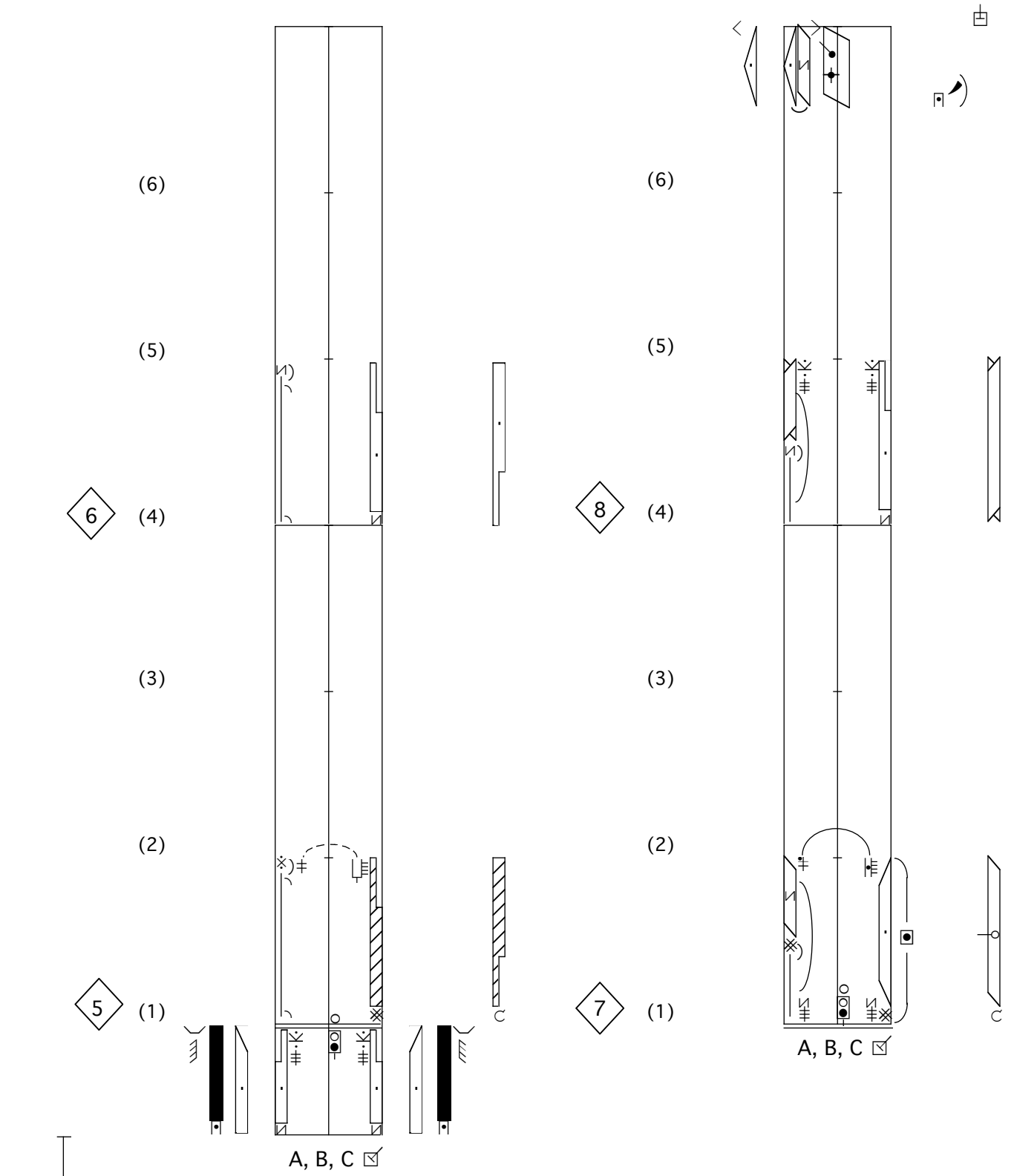

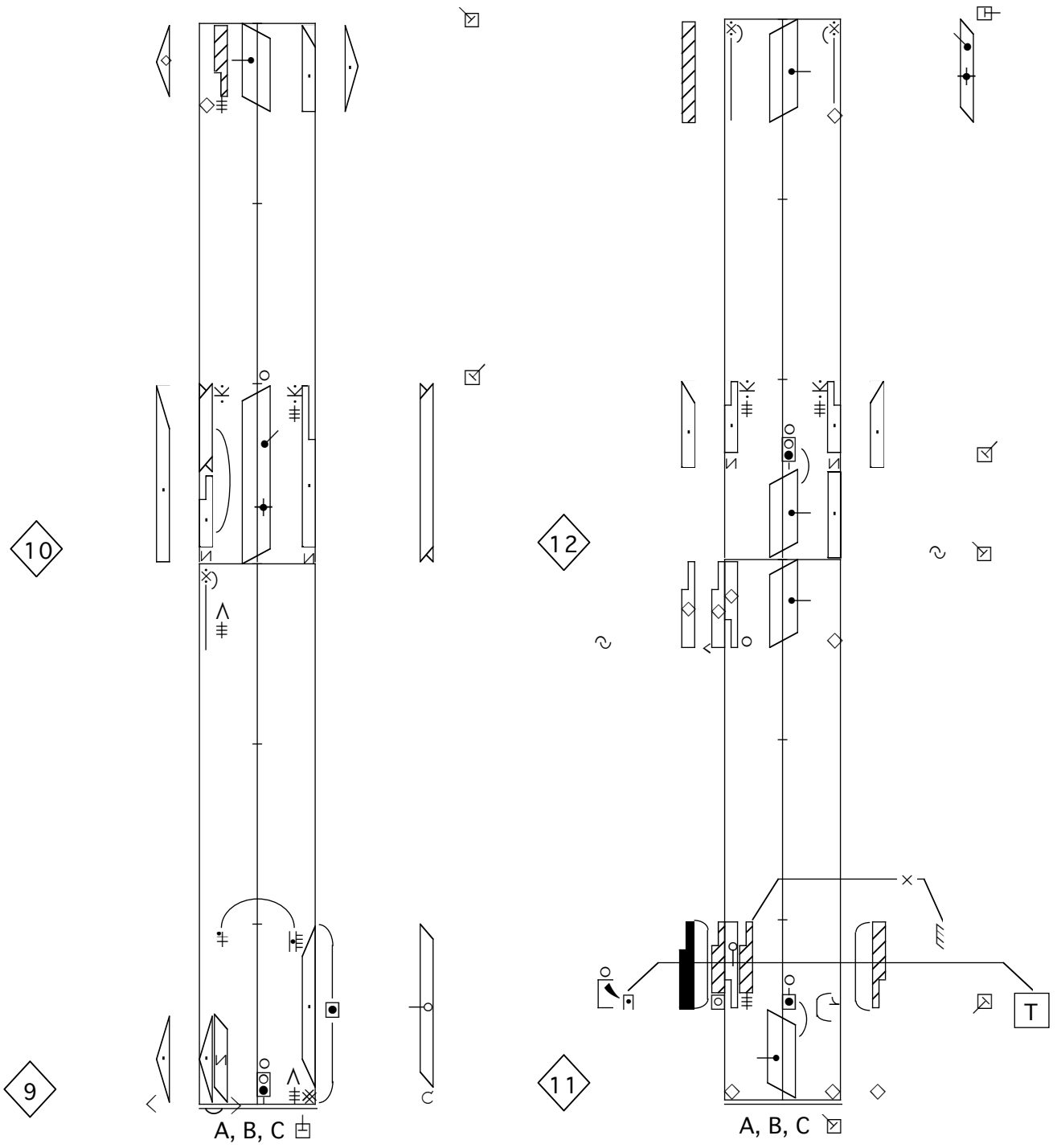

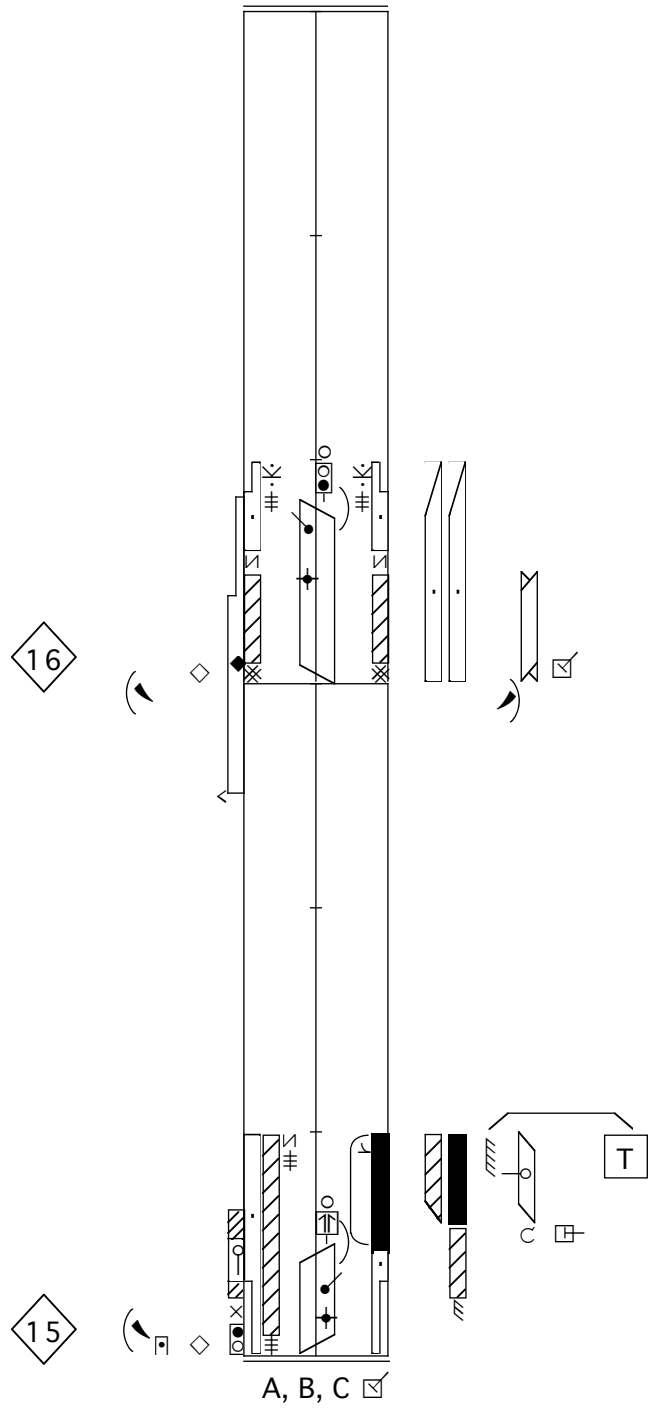
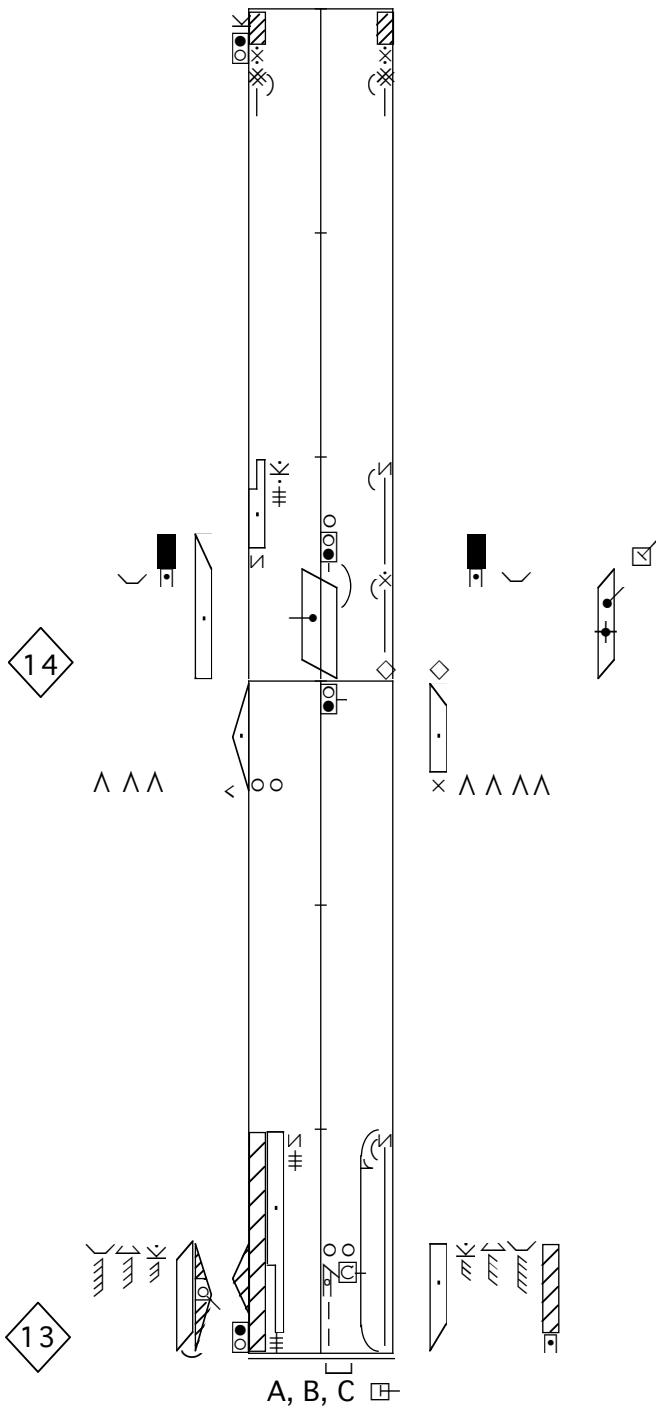

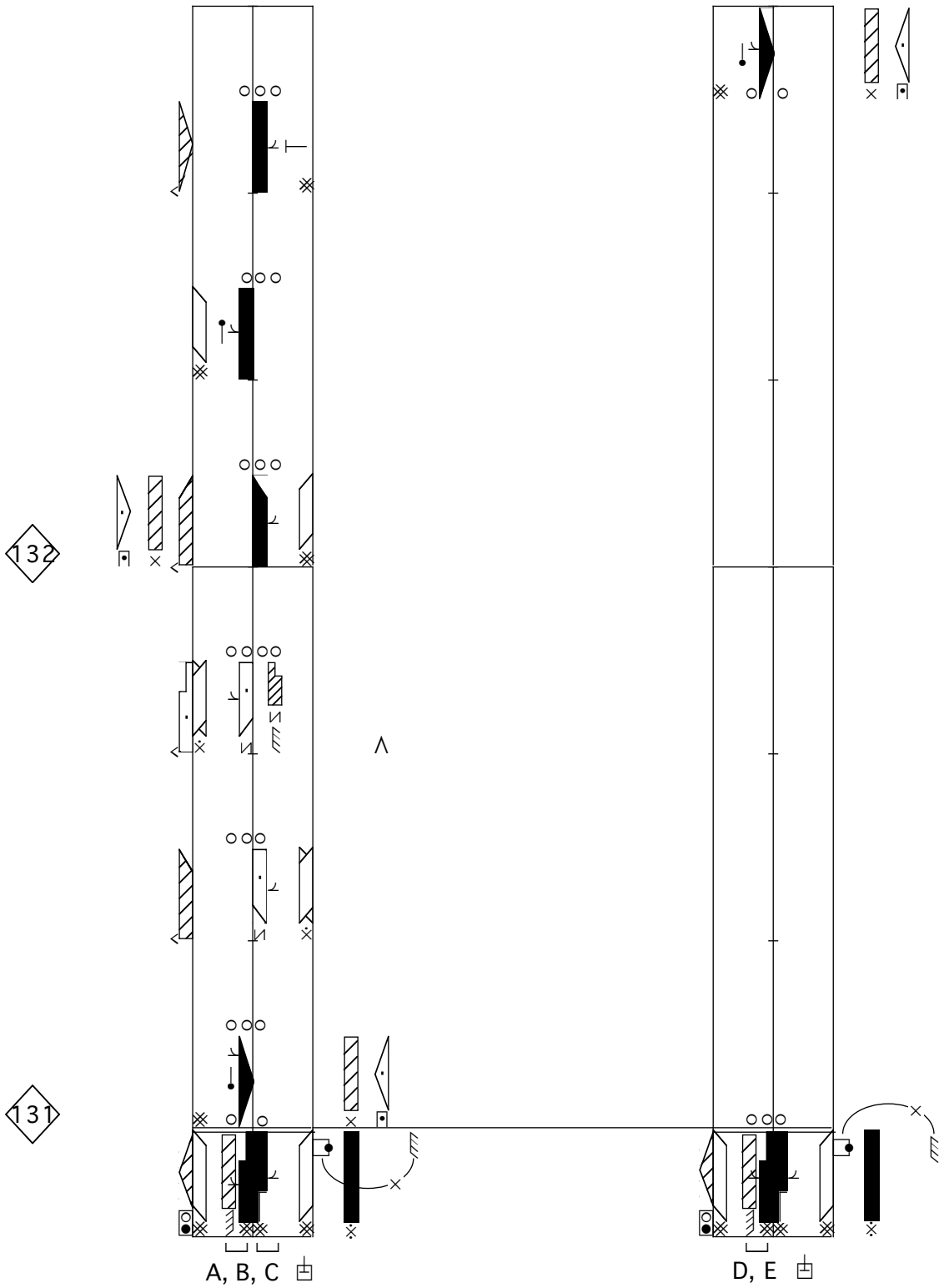

six steps

134

133



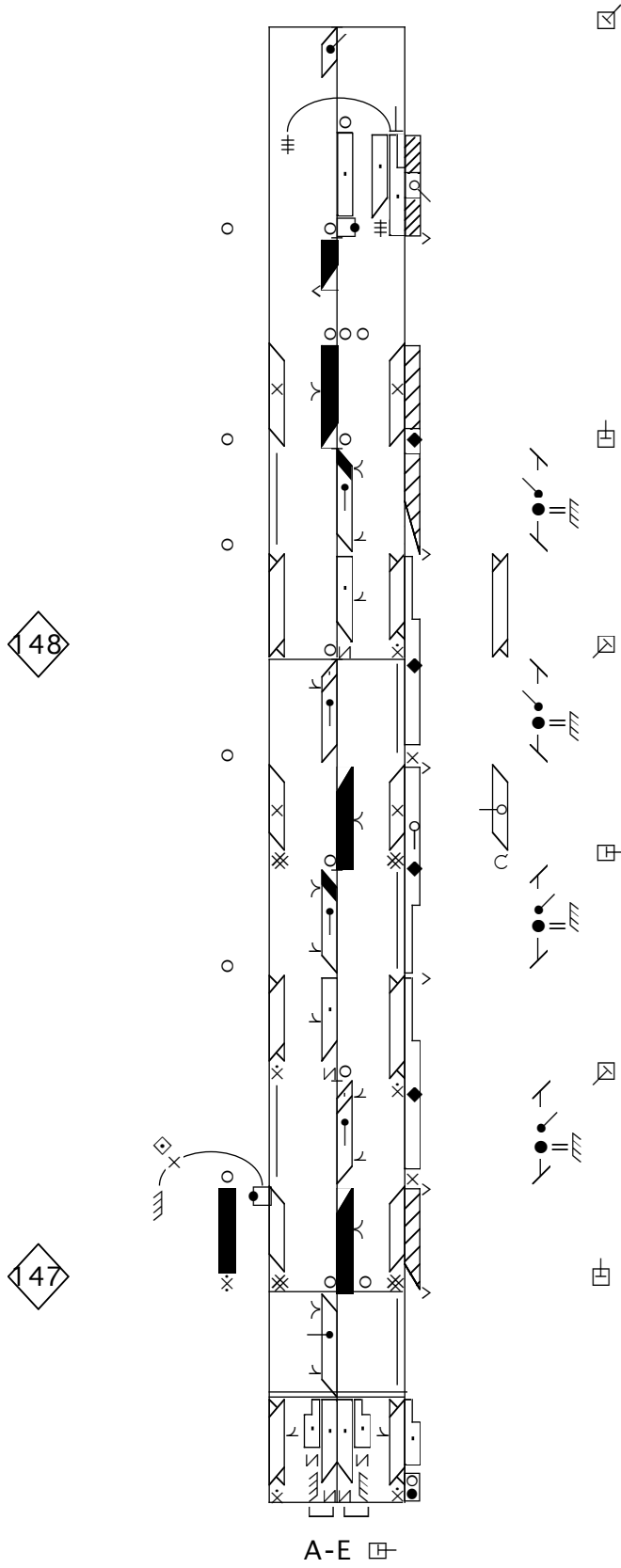

150

149

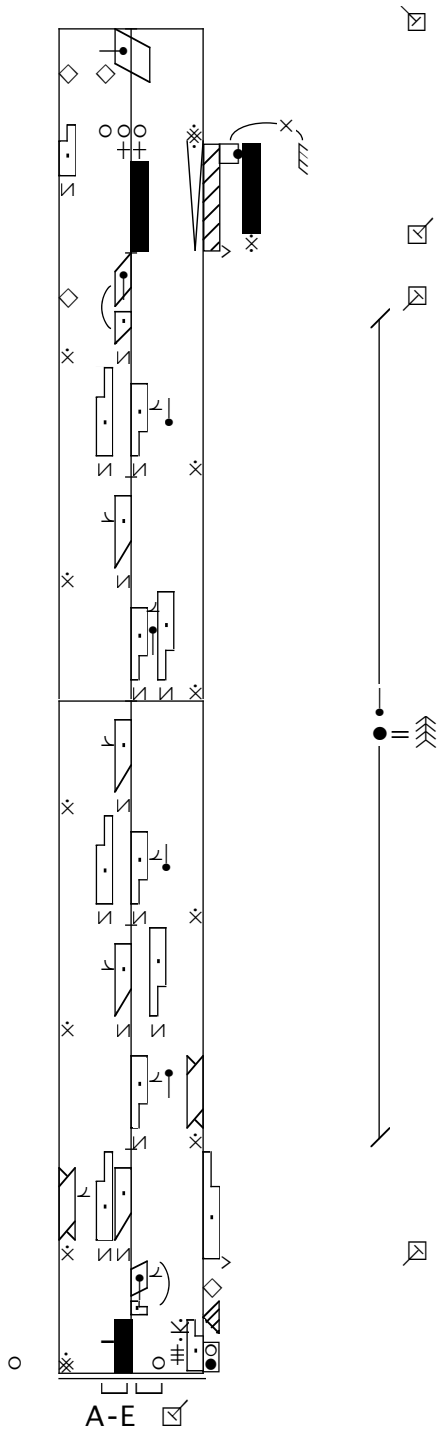

152

151

